



## SPECIFICATION SHEET

Ultramatic Model VBS-4VT Vibratory Deburring and Finishing Bowl Machine. Specified and described below. [Wet or Dry applications.](#)

SPECIFICATIONS	
Bowl Diameter	42
Channel Width	8.5
Total Capacity	4 Cu. Ft.
Load Capacity	600 Lbs.
Machine Height	38"
Machine Length	42"
Machine Width	42"
Shipping Weight	750 Lbs.
Lining: 80 Durometer	3/4 "
Input Voltage	110/1/60
Drive Unit: 1.5 HP	1800 Rpm
Specifications subject to change	



## STANDARD FEATURES

- CAST PREMIUM POLYURETHANE LINING
- DIRECT DRIVE MOTOR W/ ADJUSTABLE WEIGHTS
- HEAVY DUTY STEEL PLATE FABRICATED BOWL AND BASE
- URETHANE MOUNTED COIL SPRING SUSPENSION
- AC VARIABLE SPEED DRIVE W/ DIGITAL DISPLAY
- 110 VOLT TIMER SWITCH WITH CORDED PLUG (STAND)
- PAINT: TWILIGHT GRAY INDUSTRIAL ENAMEL
- BUILT IN PARTS UNLOAD SYSTEM (MANUAL)
- LARGE REMOVABLE SCREEN
- DISCHARGE DOOR AND REMOVABLE DRAIN
- SOLUTION INPUT VALVE
- RECEPTACLE FOR SOLUTION PUMP
- 1 YEAR WARRANTY

### ADDITIONAL STANDARD FEATURES



Includes parts unload system, screen and plug door. Wet or Dry operation

**DIRECT DRIVE SERIES** • features a Heavy Duty Vibratory Motor with easily adjustable weights. This unique design feature eliminates belts and pulleys and supplies 100 % power to the Tub. Requires 50% less HP resulting in huge electrical operation cost savings.

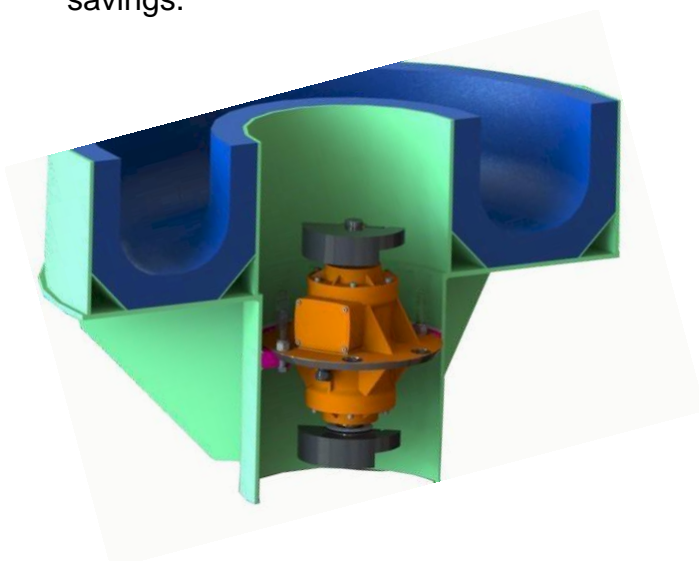



Dial In Adjustable  
Flywheels and  
Weights

110v VFD PACKAGE includes Variable  
Speed Drive, Timer, pump receptacle  
with Corded Plug mounted on a stand.



## OPTIONAL EQUIPMENT AND SUPPLIES

ST15FS Filtration System ▪ Includes 15 Gallon Tank with Cover, weirs, Filter Bag & 110-volt Recirculation Pump. Polyethylene Tank ID is 22.5" L x 17.5" W x 12" High.



We manufacture ceramic and plastic media and liquid compounds.